

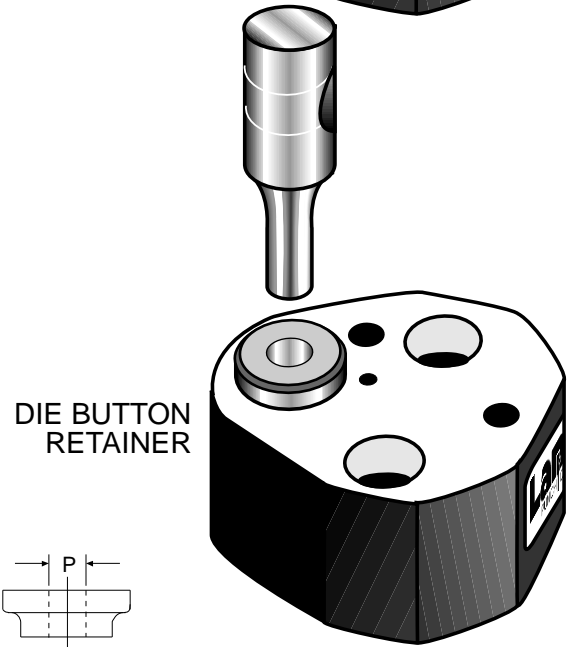

Lane **TRU-LOCK** Retainers

- Require Less Space • Offer More Strength
- Made From Through-Hardened Chrome-Vanadium Steel (AISI 6150)
  - In-Line Centering Dowel • Radial Lock Accuracy  $\pm 0^\circ 3'$
  - The Ultimate in Precision for Standard Retainers

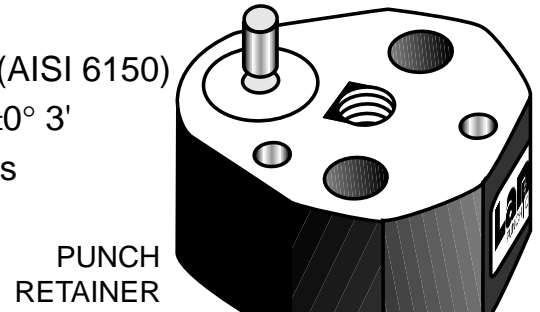
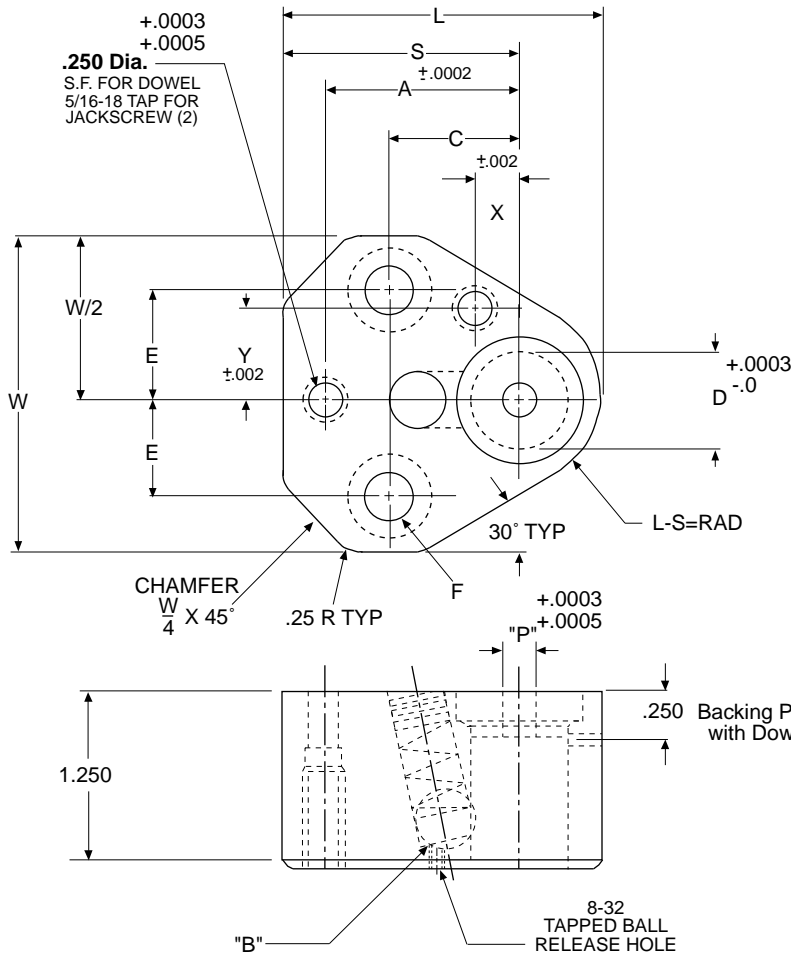

"P" DIA. SLIP FIT FOR DOWEL  
.1250 FOR BRLT 250  
.1875 FOR BRLT 375  
.2500 ALL OTHERS

Retainer set includes:  
2 Socket head cap screws.  
2 Vented and tapped dowels.  
1 Ball release set screw.

Design Templates see page SR13.  
Retainer Accessories see pages SR11-12.

**Ordering Example:**  
**(24) BRLT 500**

TYPE D	W	L	S	A	C	E	X	Y	B	F
BRLT 250	1.614	1.713	1.339	1.0600	.750	.438	.2953	.3543	.250	5/16-18
BRLT 375	1.614	1.713	1.339	1.0600	.750	.438	.2953	.3543	.250	5/16-18
BRLT 500	1.909	1.953	1.457	1.1800	.750	.562	.2559	.4724	.3125	3/8-16
BRLT 625	2.035	2.075	1.520	1.2500	.750	.625	.2362	.5315	.3125	3/8-16
BRLT 750	2.236	2.335	1.650	1.3200	.750	.688	.1969	.6496	.375	3/8-16
BRLT 875	2.236	2.455	1.710	1.4000	.750	.688	.1969	.7280	.375	3/8-16
BRLT 1000	2.539	2.713	1.839	1.6000	.938	.781	.2756	.8661	.375	1/2-13
BRLT 1250	2.539	2.713	1.839	1.6000	.938	.781	.2756	.8661	.375	1/2-13



## Lane TRU-LOCK Retainers

- Heavy Duty Tru-Lock is Recommended For Most Applications
- For Transfer Mounting, Use Lane Drill and Ream Bushings, (See Pg. SR12)

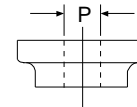
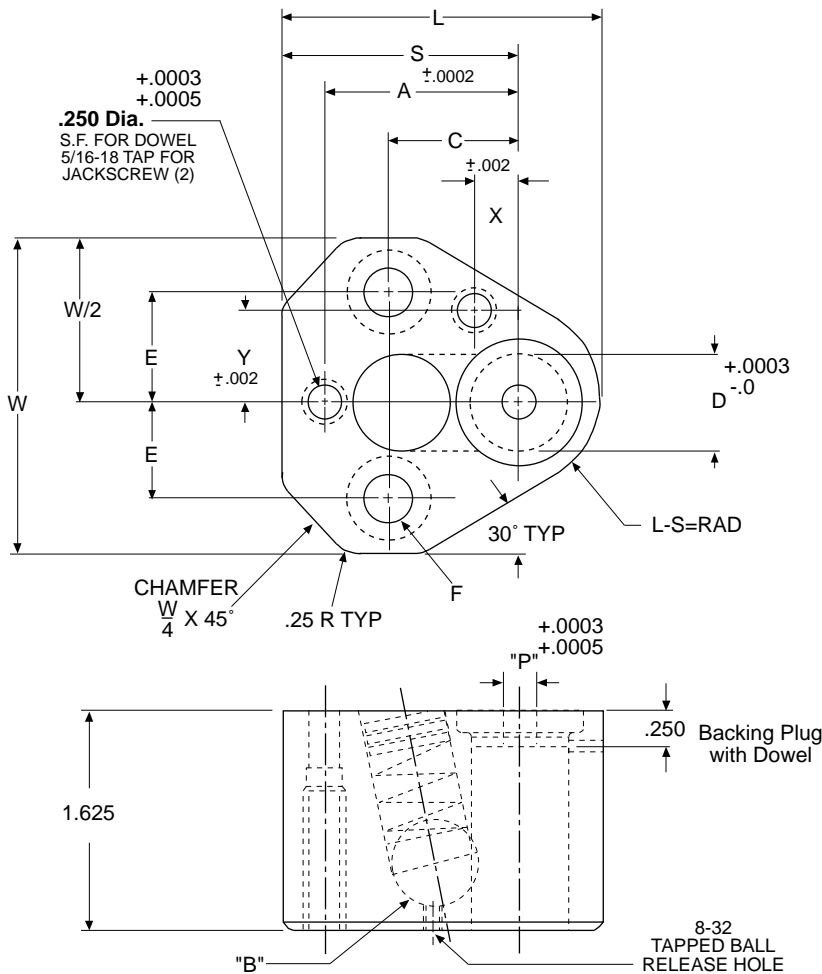

Radiused "T" Centering Type Backing Plug made from high impact shock steel. Hardened and Precision Ground.

"P" DIA. SLIP FIT FOR DOWEL  
.1875 FOR BRLT 375  
.2500 ALL OTHERS

Retainer set includes:  
2 Socket head cap screws.  
2 Vented and tapped dowels.  
1 Ball release set screw.

Ordering Example:  
**(50) BRHT 750**

Design Templates see page SR13.  
Retainer Accessories see pages SR11-12.

TYPE D	W	L	S	A	C	E	X	Y	B	F
BRHT 375	1.614	1.713	1.339	1.0600	.750	.438	.2953	.3543	.375	5/16-18
BRHT 500	1.909	1.953	1.457	1.1800	.750	.562	.2559	.4724	.500	3/8-16
BRHT 625	2.035	2.075	1.520	1.2500	.750	.625	.2362	.5315	.500	3/8-16
BRHT 750	2.236	2.335	1.650	1.3200	.750	.688	.1969	.6496	.500	3/8-16
BRHT 875	2.236	2.455	1.710	1.4000	.750	.688	.1969	.7280	.500	3/8-16
BRHT 1000	2.539	2.713	1.839	1.6000	.938	.781	.2756	.8661	.500	1/2-13
BRHT 1250	2.539	2.713	1.839	1.6000	.938	.781	.2756	.8661	.500	1/2-13



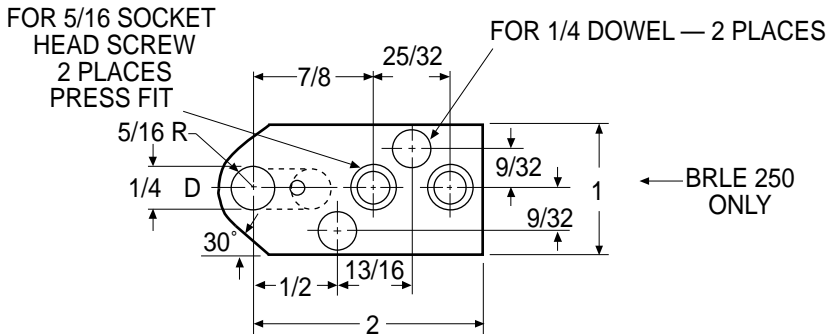

Traditional older-style 1950's technology replacement retainer for use in older dies that have not been upgraded to achieve the economic, and time saving advantages of Lane's Tru-Lock retainers listed on page SR1-2.

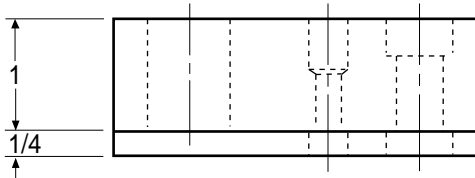
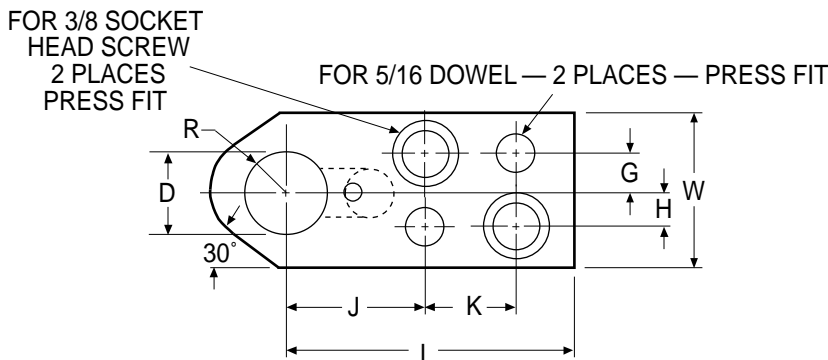
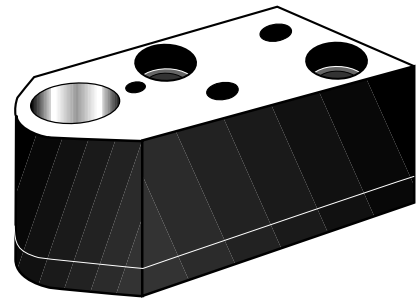

Ordering Example:  
**(3) BRLE 750**

CATALOG NUMBER	HOLE DIA. "D"	G	H	J	K	L	R	W
BRLE 250	1/4			SEE SKETCH BRLE-250				
BRLE 375	3/8	3/8	9/32	29/32	31/32	2-1/4	3/8	1-1/4
BRLE 500	1/2	3/8	9/32	29/32	31/32	2-1/4	1/2	1-1/4
BRLE 625	5/8	3/8	9/32	29/32	31/32	2-1/4	9/16	1-1/4
BRLE 750	3/4	7/16	11/32	1-1/8	1	2-1/2	11/16	1-3/8
BRLE 875	7/8	7/16	11/32	1-1/8	1	2-1/2	3/4	1-1/2
BRLE 1000	1	7/16	11/32	1-1/8	1	2-1/2	13/16	1-5/8
BRLE 1250	1-1/4	9/16	9/16	7/8	1-1/8	2-3/8	1	1-7/8

INCLUDES: RETAINER, BACKING PLATE, SOCKET HEAD & BACKING PLATE SCREWS, DOWEL PINS.

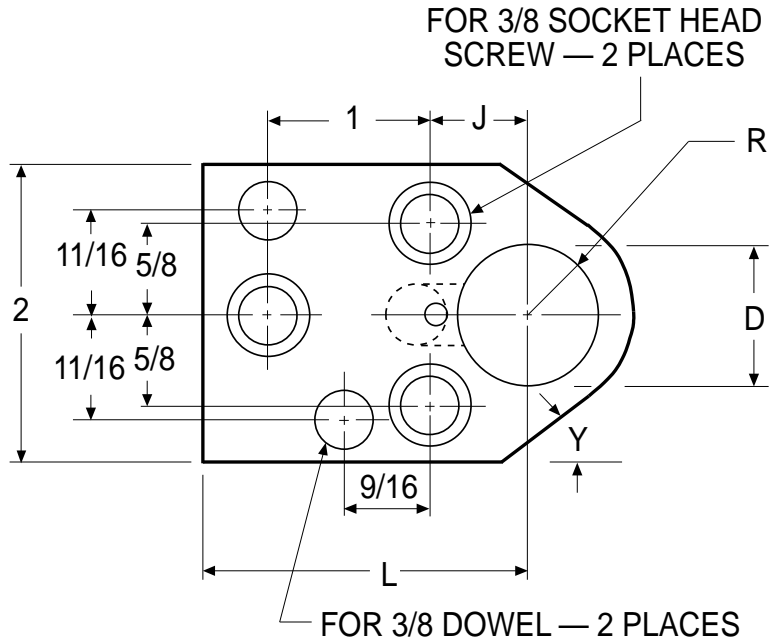

Traditional older-style 1950's technology replacement retainer for use in older dies that have not been upgraded to achieve the economic, and time saving advantages of Lane's Tru-Lock retainers listed on page SR1-2.

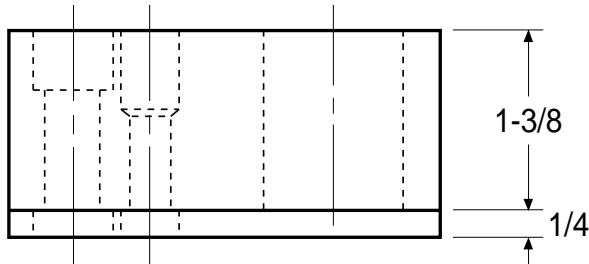
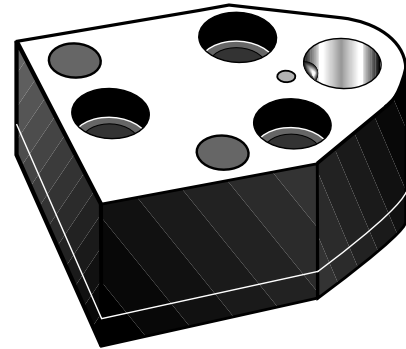

*Ordering Example:*  
**(12) BRHE 1000**

CATALOG NUMBER	HOLE DIA. "D"	J	L	R	Y
BRHE 500	1/2	3/8	1-3/4	1/2	50°
BRHE 625	5/8	7/16	1-13/16	9/16	45°
BRHE 750	3/4	1/2	1-7/8	11/16	30°
BRHE 875	7/8	9/16	1-15/16	3/4	30°
BRHE 1000	1	5/8	2	13/16	30°
BRHE 1250	1-1/4	3/4	2-1/8	1	

INCLUDES: RETAINER, BACKING PLATE, SOCKET HEAD & BACKING PLATE SCREWS, DOWEL PINS.



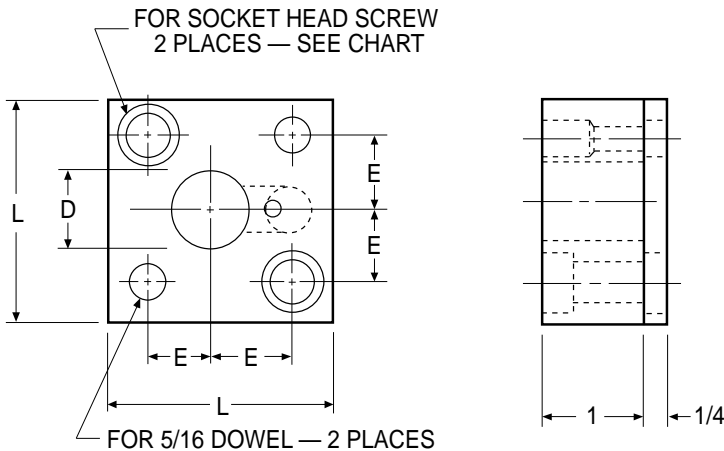

Traditional older-style 1950's technology replacement retainer for use in older dies that have not been upgraded to achieve the economic, and time saving advantages of Lane's Tru-Lock retainers listed on page SR1-2.

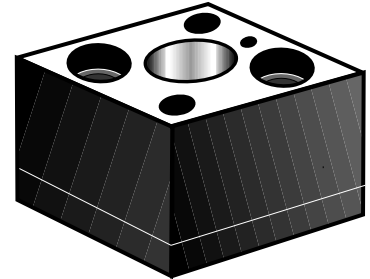

Ordering Example:  
**(6) BRLS 1250**

CATALOG NUMBER	HOLE DIA. "D"	L	E	SCREW
BRLS 250	1/4	1-1/4	5/16	1/4
BRLS 375	3/8	1-3/8	3/8	5/16
BRLS 500	1/2	1-1/2	7/16	5/16
BRLS 625	5/8	1-5/8	1/2	5/16
BRLS 750	3/4	1-7/8	9/16	3/8
BRLS 875	7/8	2	5/8	3/8
BRLS 1000	1	2-1/4	3/4	3/8
BRLS 1250	1-1/4	2-1/4	3/4	3/8
BRLS 1500	1-1/2	2-3/4	1	3/8
BRLS 1750	1-3/4	2-3/4	1	3/8

INCLUDES: RETAINER, BACKING PLATE, SOCKET HEAD & BACKING PLATE SCREWS, DOWEL PINS.

**Ball-Lock Retainer Heavy-Duty Square™**

Ordering Example:  
**(6) BRHS 750**

CATALOG NUMBER	HOLE DIA. "D"	L	E	SCREW
BRHS 500	1/2	1-7/8	9/16	3/8
BRHS 625	5/8	2	5/8	3/8
BRHS 750	3/4	2-1/8	11/16	3/8
BRHS 875	7/8	2-3/8	3/4	1/2
BRHS 1000	1	2-3/8	3/4	1/2
BRHS 1250	1-1/4	2-5/8	13/16	1/2

INCLUDES: RETAINER, BACKING PLATE, SOCKET HEAD & BACKING PLATE SCREWS, DOWEL PINS.

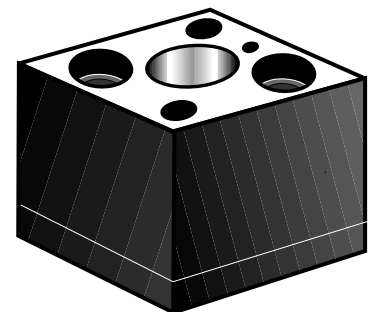

L

H

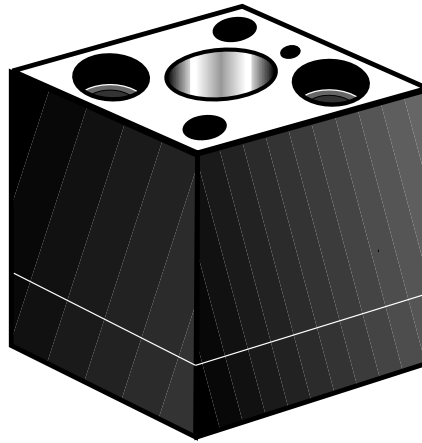
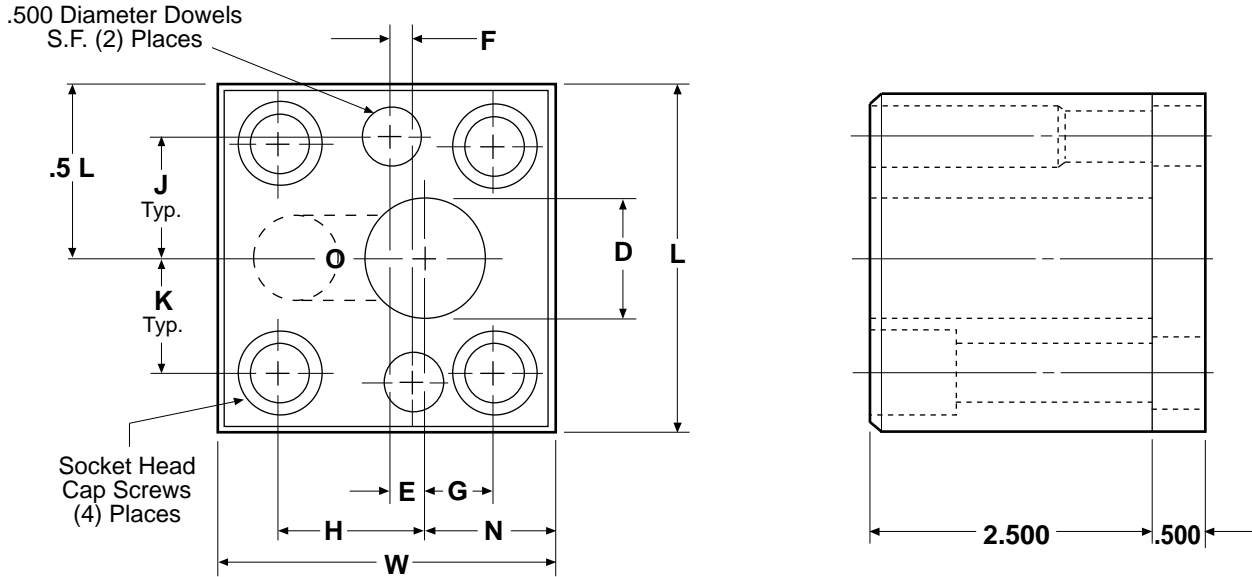

Tool Steel Rc 53-56

Stripping Force: 8400 LBS.  
Ball Diameter 3/4".

*Ordering Example*  
**(3) BRES 1500**

**EXTRA HEAVY-DUTY PUNCH RETAINER SETS (Includes hardened backing plate.)**

Catalog No.	HOLE DIA. "D"	"W"	"L"	"N"	"E"	"F"	"G"	"H"	"J"	"K"	Clearance Hole for Screw
BRES 1000	1.000	3.000	3.125	1.250	.312	.125	.687	1.187	1.125	1.062	1/2
BRES 1250	1.250	3.250	3.500	1.375	.437	.375	.812	1.312	1.250	1.187	1/2
BRES 1500	1.500	3.500	3.625	1.500	.562	.625	.937	1.437	1.375	1.312	1/2
BRES 1750	1.750	3.750	4.000	1.625	.437	.437	.937	1.437	1.500	1.312	5/8
BRES 2000	2.000	4.000	4.125	1.750	.625	.625	1.062	1.562	1.625	1.437	5/8
BRES 2250	2.250	4.250	4.500	1.875	.812	1.125	1.250	1.750	1.687	1.625	5/8
BRES 2500	2.500	4.500	4.625	2.000	.937	1.375	1.375	1.875	1.812	1.750	5/8



A Manual Solution for **Round Shoulder Punches**.  
Dowel holes are furnished **undersize**.

User locates, drills and taps mounting screw holes. After assembly and tightening of screws, dowel holes are transferred, drilled and reamed in place.

Note: Use of Lane in-line-Numerical series of punches accelerates mounting with only one dowel required on punch centerline. (See General Catalog Section.)

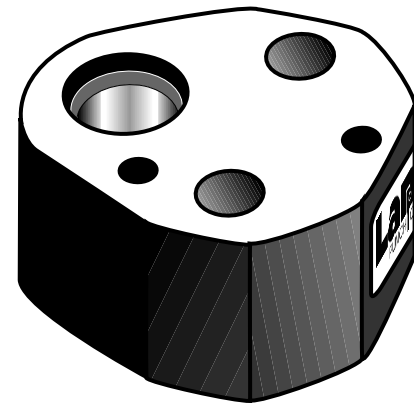
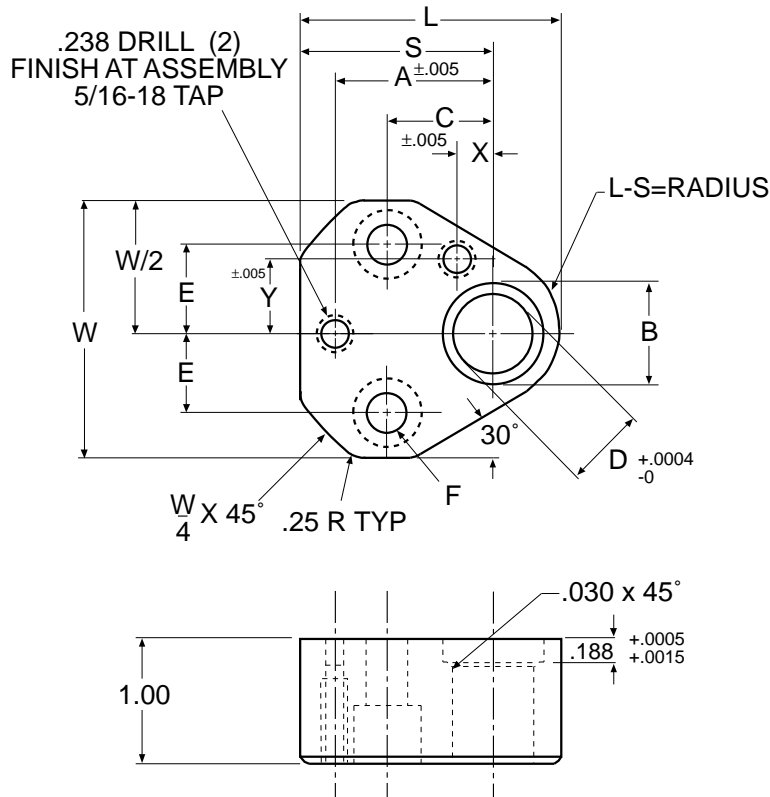

Retainer set includes:  
2 Socket head cap screws.  
2 Vented and tapped dowels.

**GRSR (ROUND POINT)**

*Ordering Example*  
**(2) GRSR 500**

**Note:** Replacement accessories, hardened and ground shim plates / Backing plates are available, page SR13.

CATALOG NO.	D	W	L	B	S	A	C	E	X	Y	F
GRSR 375	.375	1.614	1.713	.531	1.339	1.060	.750	.438	.295	.354	5/16-18
GRSR 500	.500	1.909	1.953	.656	1.457	1.180	.750	.562	.256	.472	3/8-16
GRSR 625	.625	2.035	2.075	.781	1.520	1.250	.750	.625	.236	.532	3/8-16
GRSR 750	.750	2.236	2.335	.906	1.650	1.320	.750	.688	.197	.650	3/8-16
GRSR 1000	1.000	2.539	2.713	1.156	1.839	1.600	.938	.781	.276	.866	1/2-13
GRSR 1250	1.250	2.539	2.713	1.406	1.839	1.600	.938	.781	.276	.866	1/2-13



## A Speedy Solution for *manual mounting*. Transfer dowels at assembly.

A fast manual method for locating shaped/form pointed punches without milling keys.

A standard K2 head flat orients the shape inside the retainer. User establishes location, drills and taps mounting screw holes. After assembly, proper location is checked, screws tightened, dowel holes are transferred by drilling and reaming in place.

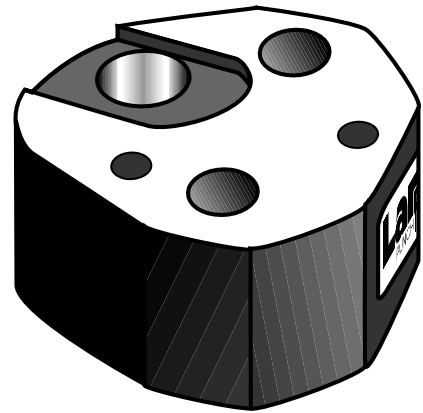
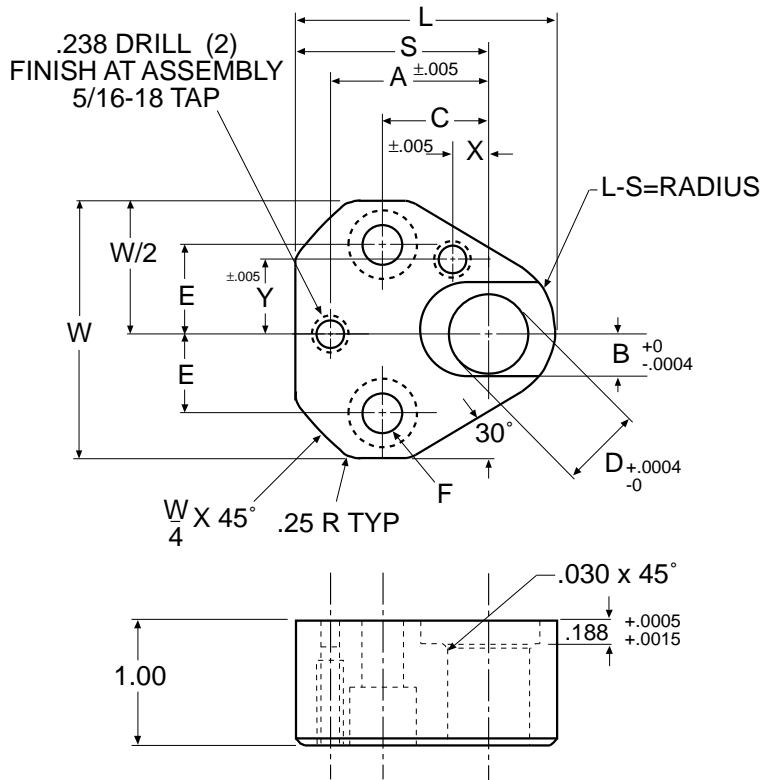

Retainer set includes:  
2 Socket head cap screws.  
2 Vented and tapped dowels.

**GRSF (FORM/SHAPED POINT)**

*Ordering Example*  
**(3) GRSF 750**

**Note:** Replacement accessories, hardened and ground shim plates / Backing plates are available, page SR13.

CATALOG NO.	D	W	L	B	S	A	C	E	X	Y	F
GRSF 375	.375	1.614	1.713	.1875	1.339	1.060	.750	.438	.295	.354	5/16-18
GRSF 500	.500	1.909	1.953	.2500	1.457	1.180	.750	.562	.256	.472	3/8-16
GRSF 625	.625	2.035	2.075	.3125	1.520	1.250	.750	.625	.236	.532	3/8-16
GRSF 750	.750	2.236	2.335	.3750	1.650	1.320	.750	.688	.197	.650	3/8-16
GRSF 1000	1.000	2.539	2.713	.5000	1.839	1.600	.938	.781	.276	.866	1/2-13
GRSF 1250	1.250	2.539	2.713	.6250	1.839	1.600	.938	.781	.276	.866	1/2-13

A Speedy Solution for **Round** Punches and pilots.  
Designed for CNC mounting method.

**Dowels are finished** and retainer is **ready to mount**.  
The counterbore is sized to accept shoulder/headed punches.

Dowel holes are also tapped to provide ease of removal by inserting jack screws in confined spaces.

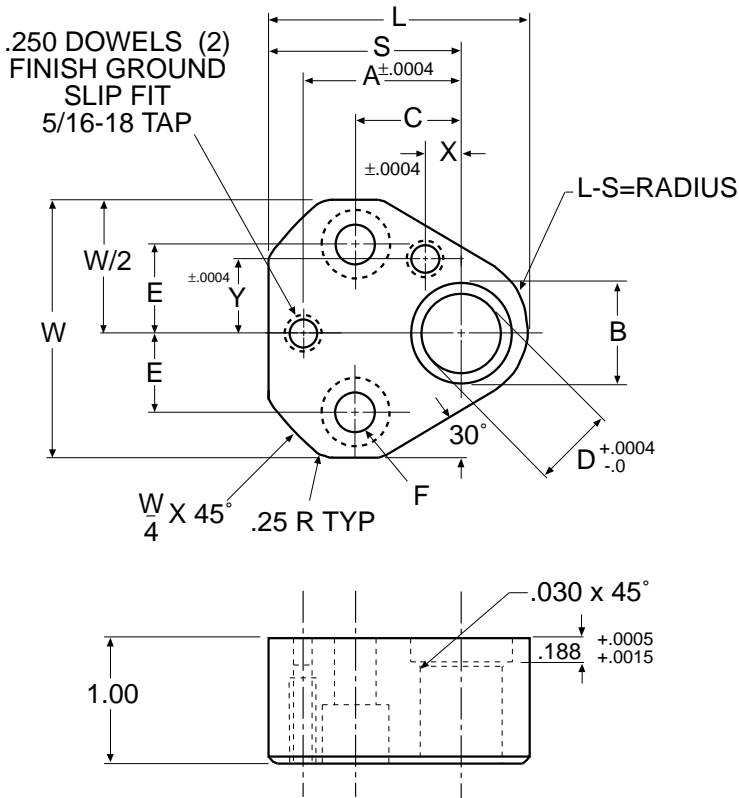

*PRSR Retainer shown with GPNR, CNC-Located Punch, Page G21.*

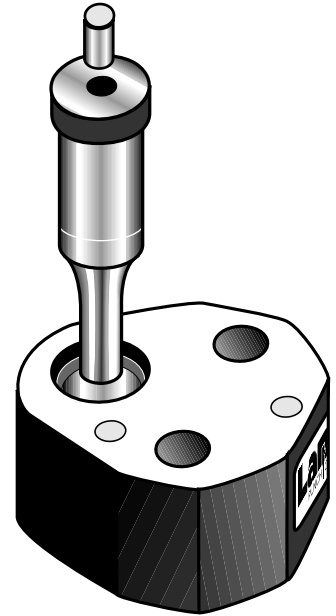

*PRSR Retainer shown with PBSR ShoulderDie Button, Page PS 23.*

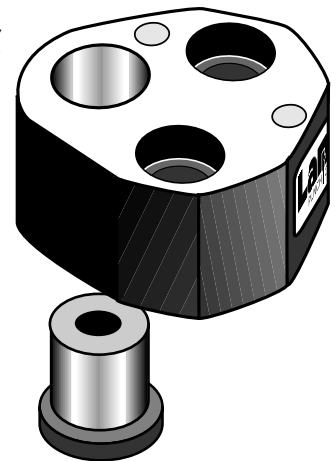

Retainer set includes:  
2 Socket head cap screws.  
2 Vented and tapped dowels.

*Ordering Example*  
**(2) PRSR 500**

**PRSR (ROUND POINT)**

**Note:** Replacement accessories, hardened and ground shim plates / Backing plates are available, page SR13.

CATALOG NO.	D	W	L	B	S	A	C	E	X	Y	F
PRSR 375	.375	1.614	1.713	.531	1.339	1.060	.750	.438	.295	.354	5/16-18
PRSR 500	.500	1.909	1.953	.656	1.457	1.180	.750	.562	.256	.472	3/8-16
PRSR 625	.625	2.035	2.075	.781	1.520	1.250	.750	.625	.236	.532	3/8-16
PRSR 750	.750	2.236	2.335	.906	1.650	1.320	.750	.688	.197	.650	3/8-16
PRSR 1000	1.000	2.539	2.713	1.156	1.839	1.600	.938	.781	.276	.866	1/2-13
PRSR 1250	1.250	2.539	2.713	1.406	1.839	1.600	.938	.781	.276	.866	1/2-13

## A Speedy Solution for *Shaped/Form* Punches. Designed for CNC mounting.

An inexpensive and very fast method. Standard K2 key flat on headed punch **orients** the shape **inside** the retainer. Your positioning of two round dowel holes in your die shoe, is all that is needed to locate complex shaped punches.  
**Retainer dowel holes are already finished to slip-fit size.**

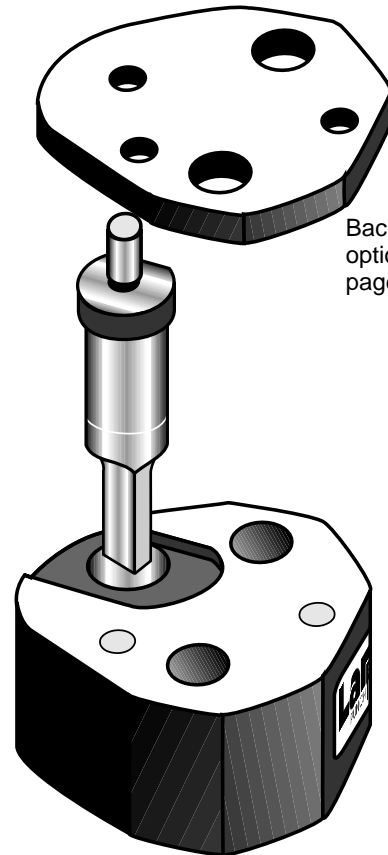
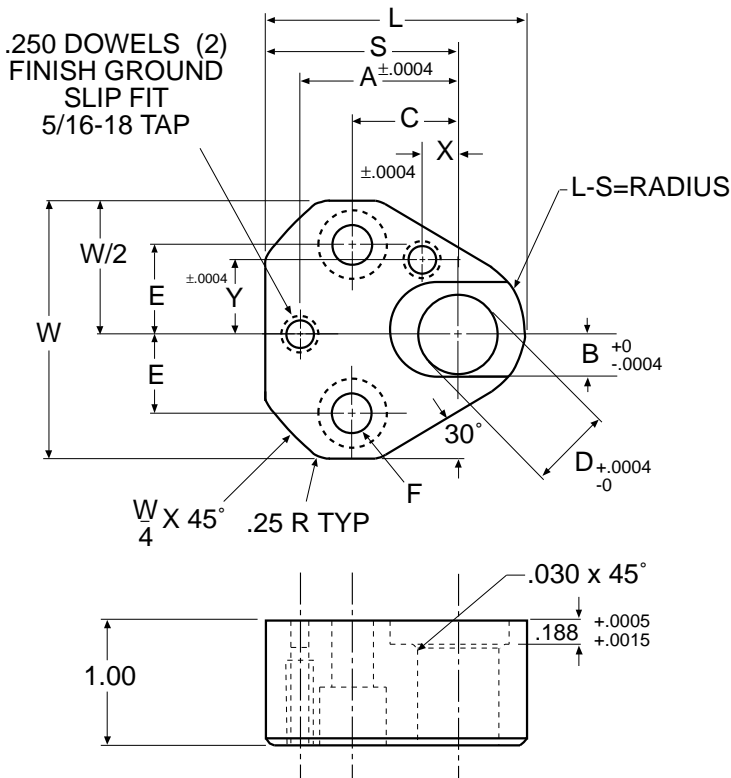

### PRSF (FORM/SHAPED POINT)

Ordering Example  
**(3) PRSF 750**

Retainer set includes:  
2 Socket head cap screws.  
2 Vented and tapped dowels.

**Note:** In-line dowel is optional in punch selection. See General Catalog Section or design your complete special.

**Note:** Replacement accessories, hardened and ground shim plates / Backing plates are available, page SR13.

CATALOG NO.	D	W	L	B	S	A	C	E	X	Y	F
PRSF 375	.375	1.614	1.713	.1875	1.339	1.060	.750	.438	.295	.354	5/16-18
PRSF 500	.500	1.909	1.953	.2500	1.457	1.180	.750	.562	.256	.472	3/8-16
PRSF 625	.625	2.035	2.075	.3125	1.520	1.250	.750	.625	.236	.532	3/8-16
PRSF 750	.750	2.236	2.335	.3750	1.650	1.320	.750	.688	.197	.650	3/8-16
PRSF 1000	1.000	2.539	2.713	.5000	1.839	1.600	.938	.781	.276	.866	1/2-13
PRSF 1250	1.250	2.539	2.713	.6250	1.839	1.600	.938	.781	.276	.866	1/2-13

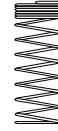
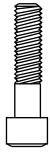

CATALOG NUMBER	SOCKET HEAD CAP SCREW	VENTED/TAPPED PULL DOWELS	BALL DIA.	BALL RELEASE SCREW	TRU-LOCK SPRING	OPTIONAL STIFF SPRING	INNER BOOSTER SPRING
BRLT 250	BA 312-150 5/16-18 x 1 1/2	BA 125-750 BA 250-750 1/8 x 3/4* 1/4 x 3/4	BA 72-250 1/4	BA 94-100 8-32 x 1	BA 81-250		
BRLT 375	BA 312-150 5/16-18 x 1 1/2	BA 187-750 BA 250-750 3/16 x 3/4* 1/4 x 3/4	BA 72-250 1/4	BA 94-100 8-32 x 1	BA 81-250		
BRLT 500	BA 375-150 3/8-16 x 1 1/2	BA 250-750 1/4 x 3/4	BA 72-312 5/16	BA 94-100 8-32 x 1	BA 81-312		
BRLT 625	BA 375-150 3/8-16 x 1 1/2	BA 250-750 1/4 x 3/4	BA 72-312 5/16	BA 94-100 8-32 x 1	BA 81-312		
BRLT 750	BA 375-150 3/8-16 x 1 1/2	BA 250-750 1/4 x 3/4	BA 72-375 3/8	BA 94-100 8-32 x 1	BA 81-375		
BRLT 875	BA 375-150 3/8-16 x 1 1/2	BA 250-750 1/4 x 3/4	BA 72-375 3/8	BA 94-100 8-32 x 1	BA 81-375		
BRLT 1000	BA 500-175 1/2-13 x 1 3/4	BA 250-750 1/4 x 3/4	BA 72-375 3/8	BA 94-100 8-32 x 1	BA 81-375		
BRLT 1250	BA 500-175 1/2-13 x 1 3/4	BA 250-750 1/4 x 3/4	BA 72-375 3/8	BA 94-100 8-32 x 1	BA 81-375		

BRHT 375	BA 312-175 5/16-18x1 3/4	BA 187-750 BA 250-750 3/16 x 3/4* 1/4 x 3/4	BA 72-375 3/8	BA 94-100 8-32 x 1	BA 82-375	BA 83-375	BA 84-375
BRHT 500	BA 375-200 3/8-16 x 2	BA 250-750 1/4 x 3/4	BA 72-500 1/2	BA 94-100 8-32 x 1	BA 82-500	BA 83-500	BA 84-500
BRHT 625	BA 375-200 3/8-16 x 2	BA 250-750 1/4 x 3/4	BA 72-500 1/2	BA 94-100 8-32 x 1	BA 82-500	BA 83-500	BA 84-500
BRHT 750	BA 375-200 3/8-16 x 2	BA 250-750 1/4 x 3/4	BA 72-500 1/2	BA 94-100 8-32 x 1	BA 82-500	BA 83-500	BA 84-500
BRHT 875	BA 375-200 3/8-16 x 2	BA 250-750 1/4 x 3/4	BA 72-500 1/2	BA 94-100 8-32 x 1	BA 82-500	BA 83-500	BA 84-500
BRHT 1000	BA 500-200 1/2-13 x 2	BA 250-750 1/4 x 3/4	BA 72-500 1/2	BA 94-100 8-32 x 1	BA 82-500	BA 83-500	BA 84-500
BRHT 1250	BA 500-200 1/2-13 x 2	BA 250-750 1/4 x 3/4	BA 72-500 1/2	BA 94-100 8-32 x 1	BA 82-500	BA 83-500	BA 84-500

\* 1/8" AND 3/16" DOWELS ARE NOT TAPPED / VENTED.

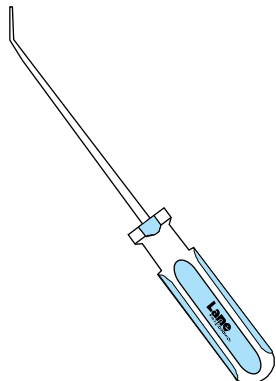

**SR11**

**RTA**  
RELEASE TOOL ANGULAR

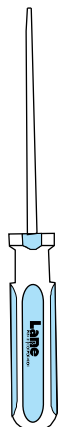

**RTS**  
RELEASE TOOL STRAIGHT



**RTT**  
RELEASE TOOL THREADED

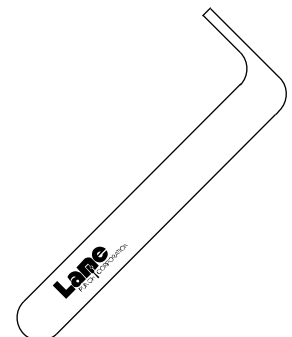

**RTJ**  
RELEASE TOOL JIMMY

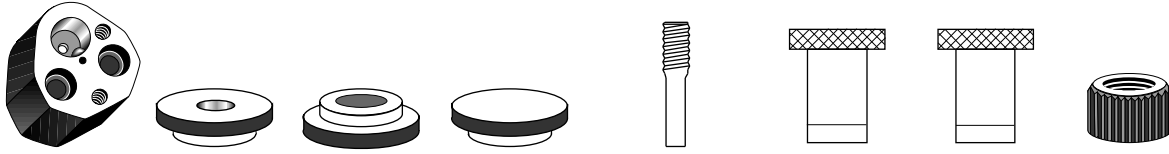

CATALOG NUMBER	BACKING PLUGS			JACK SCREW	For Manual Mounting, prevents chips from entering spring / ball hole.		RETAINER NUTS
	IN LINE DOWEL PLUG	DIE BUTTON PLUG	SOLID PLUG		DRILL BUSHING	REAM BUSHING	
BRLT 250	BA 91-250 .125 hole		BA 93-250 solid	BA 96-125 5/16-18 x 1 1/4	RDB-250	RRB-250	RN-312
BRLT 375	BA 91-375 .1875 hole		BA 93-375 solid	BA 96-125 5/16-18 x 1 1/4	RDB-375	RRB-375	RN-312
BRLT 500	BA 91-500 .250 hole	BA 92-500 .312 hole	BA 93-500 solid	BA 96-125 5/16-18 x 1 1/4	RDB-500	RRB-500	RN-375
BRLT 625	BA 91-625 .250 hole	BA 92-625 .406 hole	BA 93-625 solid	BA 96-125 5/16-18 x 1 1/4	RDB-625	RRB-625	RN-375
BRLT 750	BA 91-750 .250 hole	BA 92-750 .531 hole	BA 93-750 solid	BA 96-125 5/16-18 x 1 1/4	RDB-750	RRB-750	RN-375
BRLT 875	BA 91-875 .250 hole	BA 92-875 .625 hole	BA 93-875 solid	BA 96-125 5/16-18 x 1 1/4	RDB-875	RRB-875	RN-375
BRLT 1000	BA 91-1000 .250 hole	BA 92-1000 .719 hole	BA 93-1000 solid	BA 96-125 5/16-18 x 1 1/4	RDB-1000	RRB-1000	RN-500
BRLT 1250	BA 91-1250 .250 hole	BA 92-1250 .812 hole	BA 93-1250 solid	BA 96-125 5/16-18 x 1 1/4	RDB-1250	RRB-1250	RN-500

BRHT 375	BA 91-375 .1875 hole		BA 93-375 solid	BA 96-125 5/16-18 x 1 1/4	RDB-375	RRB-375	RN-312
BRHT 500	BA 91-500 .250 hole		BA 93-500 solid	BA 96-125 5/16-18 x 1 1/4	RDB-500	RRB-500	RN-375
BRHT 625	BA 91-625 .250 hole		BA 93-625 solid	BA 96-125 5/16-18 x 1 1/4	RDB-625	RRB-625	RN-375
BRHT 750	BA 91-750 .250 hole		BA 93-750 solid	BA 96-125 5/16-18 x 1 1/4	RDB-750	RRB-750	RN-375
BRHT 875	BA 91-875 .250 hole		BA 93-875 solid	BA 96-125 5/16-18 x 1 1/4	RDB-875	RRB-875	RN-375
BRHT 1000	BA 91-1000 .250 hole		BA 93-1000 solid	BA 96-125 5/16-18 x 1 1/4	RDB-1000	RRB-1000	RN-500
BRHT 1250	BA 91-1250 .250 hole		BA 93-1250 solid	BA 96-125 5/16-18 x 1 1/4	RDB-1250	RRB-1250	RN-500

*Shoulder* Punch Retainer Accessories are on page SR 13.

**SPRINGS FOR BACKING PLATE STYLE RETAINERS**



**250 S**  
**1/4 SPRING**



**312 S**  
**5/16 SPRING**



**375 S**  
**3/8 SPRING**

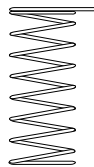

**500 S**  
**1/2 SPRING**

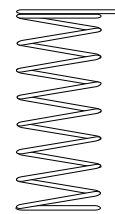

**750 S**  
**3/4 SPRING**



**BA 72-750**  
**3/4 BALL**

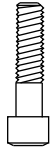

CATALOG NUMBER	CATALOG NUMBER	SOCKET HEAD CAP SCREW	VENTED/TAPPED PULL DOWELS	JACK SCREW	BACKING PLATE	SHIM PLATE	RETAINER NUTS
PRS_ 375	GRS_ 375	BA 312-150 5/16-18 x 1 1/2	BA 250-750 1/4 x 3/4"	BA 96-125 5/16-18 x 1 1/4	GBP 375 3/16 thick	GSP 375 1/16 thick	RN-312
PRS_ 500	GRS_ 500	BA 375-150 3/8-16 x 1 1/2	BA 250-750 1/4 x 3/4"	BA 96-125 5/16-18 x 1 1/4	GBP 500 3/16 thick	GSP 500 1/16 thick	RN-375
PRS_ 625	GRS_ 625	BA 375-150 3/8-16 x 1 1/2	BA 250-750 1/4 x 3/4"	BA 96-125 5/16-18 x 1 1/4	GBP 625 3/16 thick	GSP 625 1/16 thick	RN-375
PRS_ 750	GRS_ 750	BA 375-150 3/8-16 x 1 1/2	BA 250-750 1/4 x 3/4"	BA 96-125 5/16-18 x 1 1/4	GBP 750 3/16 thick	GSP 750 1/16 thick	RN-375
PRS_ 1000	GRS_ 1000	BA 500-175 1/2-13 x 1 3/4	BA 250-750 1/4 x 3/4"	BA 96-125 5/16-18 x 1 1/4	GBP 1000 3/16 thick	GSP 1000 1/16 thick	RN-500
PRS_ 1250	GRS_ 1250	BA 500-175 1/2-13 x 1 3/4	BA 250-750 1/4 x 3/4"	BA 96-125 5/16-18 x 1 1/4	GBP 1250 3/16 thick	GSP 1250 1/16 thick	RN-500

TRU-LOCK Retainer Accessories are on Page SR 11-12.

## Design Package

### TRU-LOCK<sup>®</sup>

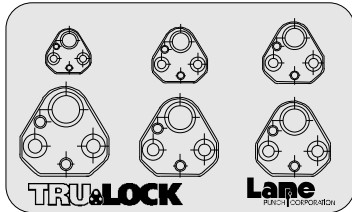

Full scale design template:  
BA 70

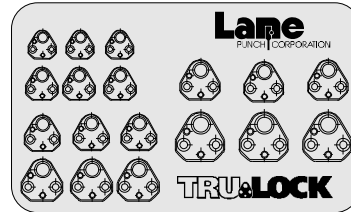

Reduced scale design template:  
BA 71  
1/2 1/3 1/4 scale

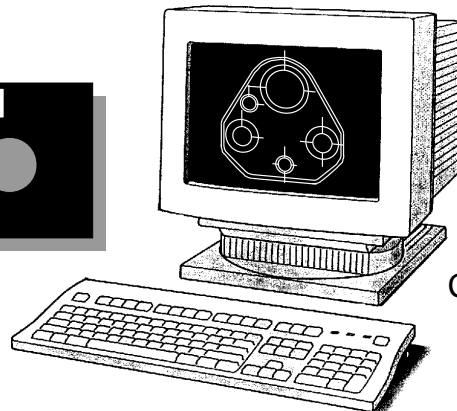
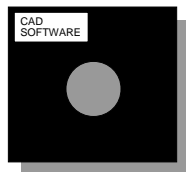

Lane CAD  
Electronic design package  
IGES Format  
Contact our Sales-Engineering staff.